

REVISION RECORD				
REV	ECO	DESCRIPTION	DRFT	CHKD
△		Add P/N	hammy 06/09/04	

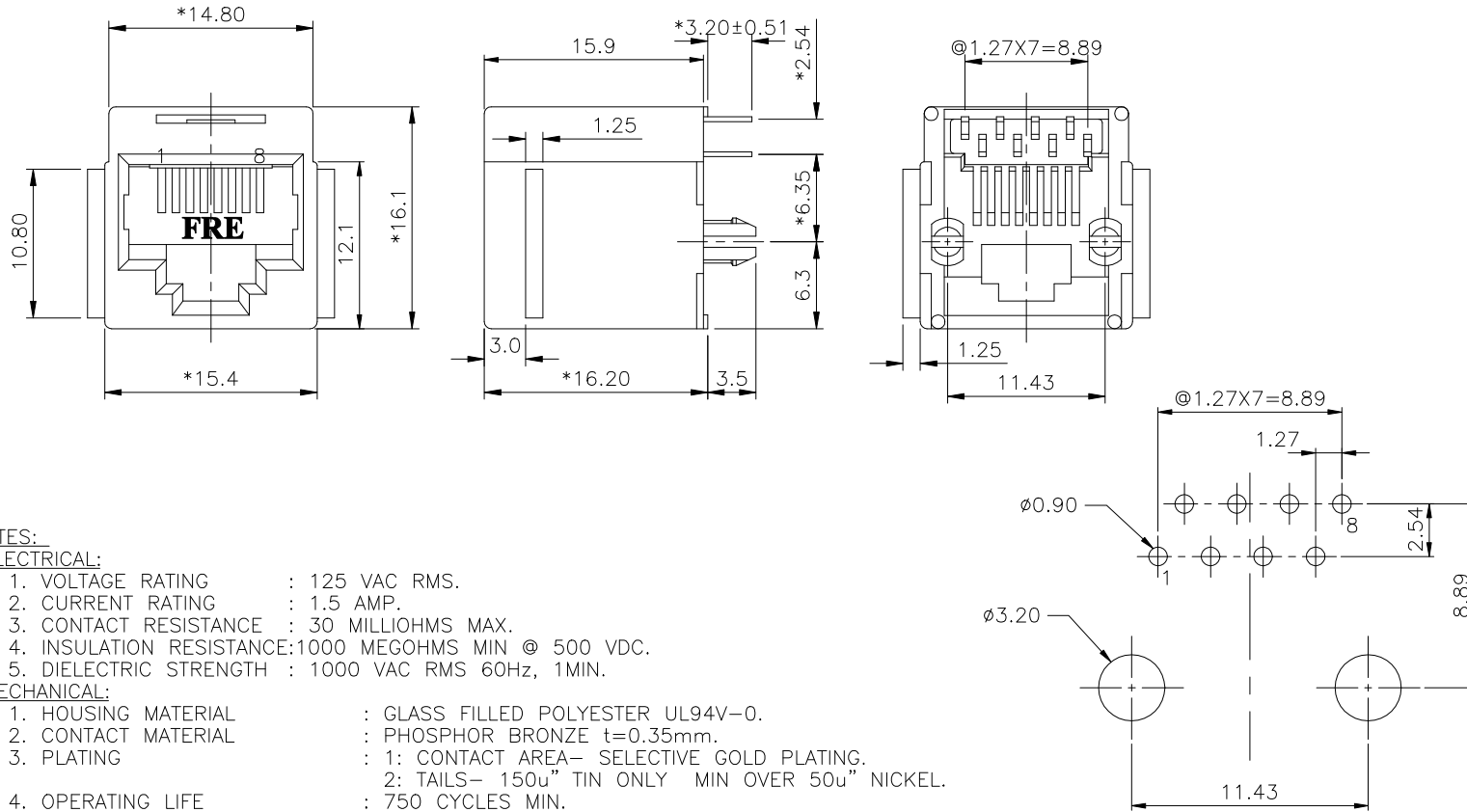

NOTES:

ELECTRICAL:

- VOLTAGE RATING : 125 VAC RMS.
- CURRENT RATING : 1.5 AMP.
- CONTACT RESISTANCE : 30 MILLIOHMS MAX.
- INSULATION RESISTANCE:1000 MEGOHMS MIN @ 500 VDC.
- DIELECTRIC STRENGTH : 1000 VAC RMS 60Hz, 1MIN.

MECHANICAL:

- HOUSING MATERIAL : GLASS FILLED POLYESTER UL94V-0.
- CONTACT MATERIAL : PHOSPHOR BRONZE t=0.35mm.
- PLATING : 1: CONTACT AREA- SELECTIVE GOLD PLATING.
2: TAILS- 150u" TIN ONLY MIN OVER 50u" NICKEL.
- OPERATING LIFE : 750 CYCLES MIN.
- PCB RETENTION PRE-SOLDER : 1 LB MIN.
- PCB RETENTION POST-SOLDER: 10 LBS MIN.

ENVIRONMENTAL:

- STORAGE : -40°C TO +85°C.
- OPERATION: 0°C TO 70°C.

MATES WITH MODULAR PLUG CONFORMING TO FCC PART 68, SUBPART F.

CUL FILE NO. E163191

PART NUMBER: E5288-X00BXX-L

- △ 3-W/ FRE LOGO
- R-W/O FRE LOGO
- 1- 3u" 2- 6u"
- 3-15u" 4-30u"
- 5-50u"
- 3-W/ PANNEL STOP △
- 4-W/O PANNEL STOP

PC Board Layout Component Side Shown

DETACHED LISTS	← MM (INCH) →	DFTO syngs	DATE 02/23/04	FULL RISE ELECTRONIC CO., LTD		
	TOLERANCES EXCEPT AS NOTED	CHKD HERO	DATE 2004/6/9			
	MM	MFO	DATE	TITLE (IMPROVED TYPE&LEAD_FREE) RJ45 TOP ENTRY PCB JACK		
	.0 ± 0.2 ±	APPLV CZH	DATE 2004/6/9			
	.00 ± 0.15 ±	MATERIAL :		DRAWING NO. GE523108 /PART NO. SEE NOTE		
	.000 ± 0.075 ±	ANGLES ± 0.5				
	THIRD ANGLE PROJECTION	QT'Y :	DO NOT SCALE DRAWING		SHEET	OF
		FINISH :				
		SCALE :	SIZE REV A3 1			